

Fig. 1-3 Angular Units

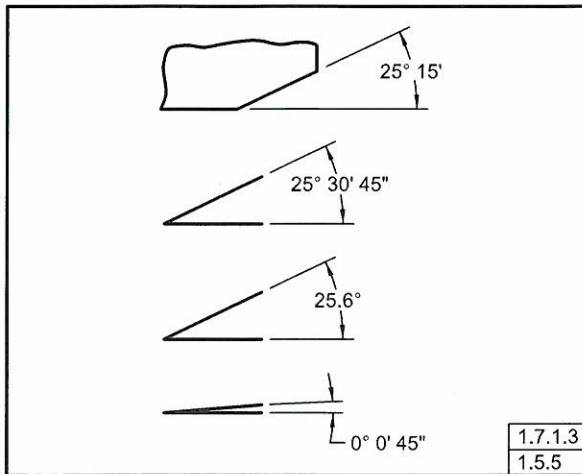

Fig. 1-5 Decimal Inch Dimensions

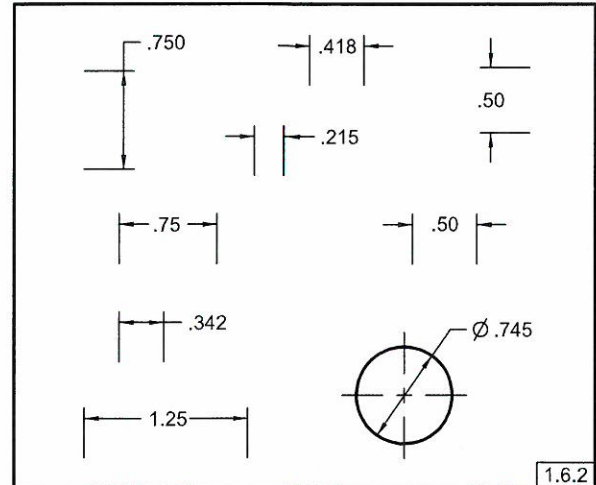
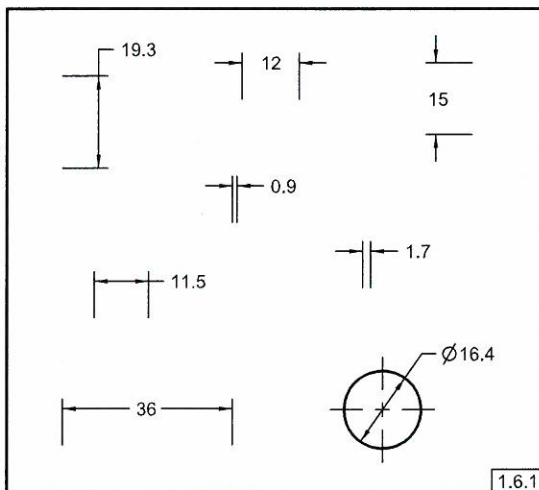

Fig. 1-4 Millimeter Dimensions



1.5.5 Angular Units

Angular dimensions are expressed in both degrees and decimal parts of a degree or in degrees, minutes, and seconds. These latter dimensions are expressed by the following symbols:

- (a) degrees: °
- (b) minutes: '
- (c) seconds: ''

Where degrees are indicated alone, the numerical value shall be followed by the symbol. Where only minutes or seconds are specified, the number of minutes or seconds shall be preceded by 0° or 0°0', as applicable. Where decimal degrees less than one are specified, a zero shall precede the decimal value. See Fig. 1-3.

1.6 TYPES OF DIMENSIONING

Decimal dimensioning shall be used on drawings except where certain commercial commodities are identified by standardized nominal size designations, such as pipe and lumber sizes.

1.6.1 Millimeter Dimensioning

The following shall be observed where specifying millimeter dimensions on drawings:

- (a) Where the dimension is less than one millimeter, a zero precedes the decimal point. See Fig. 1-4.
- (b) Where the dimension is a whole number, neither the decimal point nor a zero is shown. See Fig. 1-4.
- (c) Where the dimension exceeds a whole number by a decimal fraction of one millimeter, the last digit to the right of the decimal point is not followed by a zero. See Fig. 1-4.

NOTE: This practice differs for tolerances expressed bilaterally or as limits. See paras. 2.3.1(b) and (c).

- (d) Neither commas nor spaces shall be used to separate digits into groups in specifying millimeter dimensions on drawings.

1.6.2 Decimal Inch Dimensioning

The following shall be observed where specifying decimal inch dimensions on drawings:

- (a) A zero is not used before the decimal point for values less than 1 in.
- (b) A dimension is expressed to the same number of decimal places as its tolerance. Zeros are added to the right of the decimal point where necessary. See Fig. 1-5 and para. 2.3.2.

Fig. 1-6 Application of Dimensions

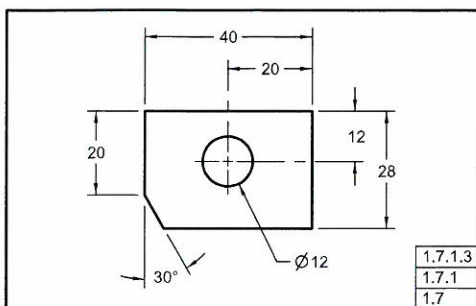

Fig. 1-8 Spacing of Dimension Lines

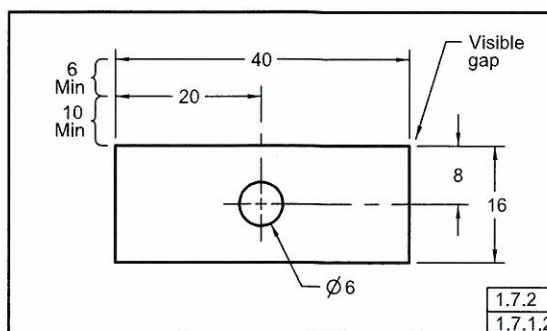

Fig. 1-7 Grouping of Dimensions

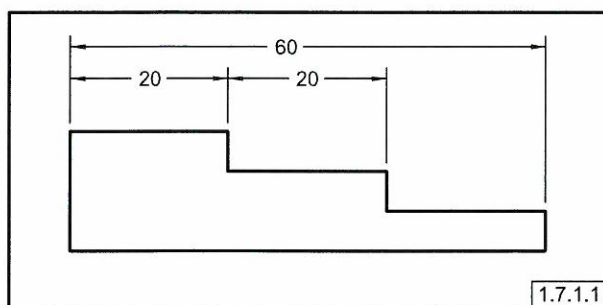
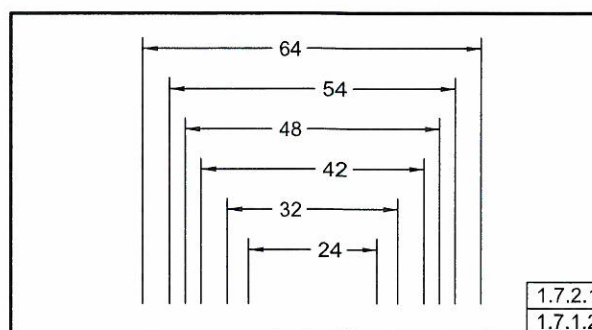

Fig. 1-9 Staggered Dimensions



1.6.3 Decimal Points

Decimal points must be uniform, dense, and large enough to be clearly visible and meet the reproduction requirements of ASME Y14.2M. Decimal points are placed in line with the bottom of the associated digits.

1.6.4 Conversion and Rounding of Linear Units

For information on conversion and rounding of U.S. Customary linear units, see IEEE/ASTM SI 10.

1.7 APPLICATION OF DIMENSIONS

Dimensions are applied by means of dimension lines, extension lines, chain lines, or a leader from a dimension, note, or specification directed to the appropriate feature. See Fig. 1-6. General notes are used to convey additional information. For further information on dimension lines, extension lines, chain lines, and leaders, see ASME Y14.2.

1.7.1 Dimension Lines

A dimension line, with its arrowheads, shows the direction and extent of a dimension. Numerals indicate the number of units of a measurement. Preferably, dimension lines should be broken for insertion of numerals as

shown in Fig. 1-6. Where horizontal dimension lines are not broken, numerals are placed above and parallel to the dimension lines.

NOTE: The following shall not be used as a dimension line: a center line, an extension line, a phantom line, a line that is part of the outline of the object, or a continuation of any of these lines. A dimension line is not used as an extension line, except where a simplified method of coordinate dimensioning is used to define curved outlines. See Fig. 1-35

1.7.1.1 Alignment. Dimension lines shall be aligned if practicable and grouped for uniform appearance. See Fig. 1-7.

1.7.1.2 Spacing. Dimension lines are drawn parallel to the direction of measurement. The space between the first dimension line and the part outline should be not less than 10 mm; the space between succeeding parallel dimension lines should be not less than 6 mm. See Fig. 1-8.

NOTE: These spacings are intended as guides only. If the drawing meets the reproduction requirements of the accepted industry or military reproduction specification, nonconformance to these spacing requirements is not a basis for rejection of the drawing.

Where there are several parallel dimension lines, the numerals should be staggered for easier reading. See Fig. 1-9.

Fig. 1-10 Oblique Extension Lines

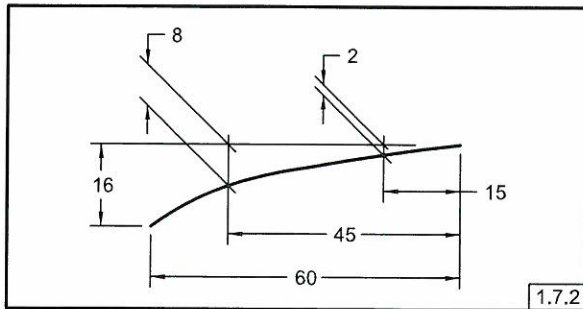

Fig. 1-11 Breaks in Extension Lines

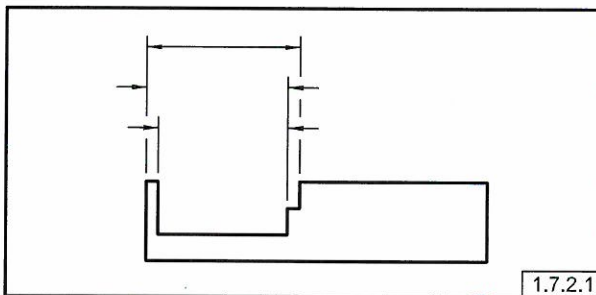
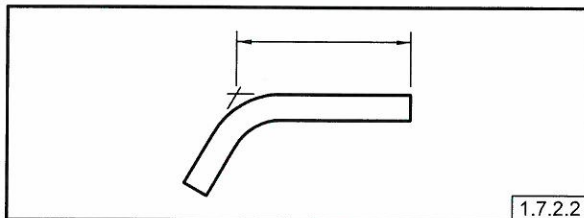

Fig. 1-12 Point Locations



1.7.1.3 Angle Dimensions. The dimension line of an angle is an arc drawn with its center at the apex of the angle. The arrowheads terminate at the extensions of the two sides. See Figs. 1-3 and 1-6.

1.7.1.4 Crossing Dimension Lines. Crossing dimension lines should be avoided. Where unavoidable, the dimension lines are unbroken.

1.7.2 Extension (Projection) Lines

Extension lines are used to indicate the extension of a surface or point to a location preferably outside the part outline. See para. 1.7.8. On 2D orthographic drawings, extension lines start with a short visible gap from the outline of the part and extend beyond the outermost related dimension line. See Fig. 1-8. Extension lines are drawn

Fig. 1-13 Limited Length or Area Indication

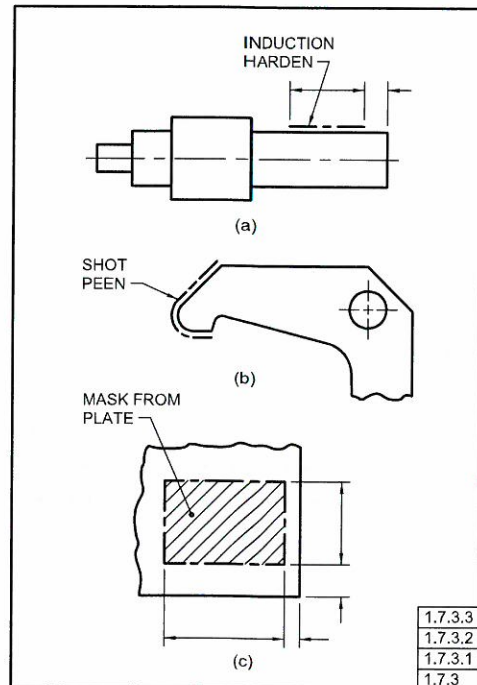

perpendicular to dimension lines. Where space is limited, extension lines may be drawn at an oblique angle to clearly illustrate where they apply. Where oblique lines are used, the dimension lines are shown in the direction in which they apply. See Fig. 1-10.

1.7.2.1 Crossing Extension Lines. Wherever practicable, extension lines should neither cross one another nor cross dimension lines. To minimize such crossings, the shortest dimension line is shown nearest the outline of the object. See Fig. 1-9. Where extension lines must cross other extension lines, dimension lines, or lines depicting features, they are not broken. Where extension lines cross arrowheads or dimension lines close to arrowheads, a break in the extension line is permissible. See Fig. 1-11.

1.7.2.2 Locating Points or Intersections. Where a point is located by extension lines only, the extension lines from surfaces should pass through the point or intersection. See Fig. 1-12.

1.7.3 Limited Length or Area Indication

Where it is desired to indicate that a limited length or area of a surface is to receive additional treatment or consideration within limits specified on the drawing, the extent of these limits may be indicated by use of a chain line. See Fig. 1-13.

Fig. 1-14 Leaders

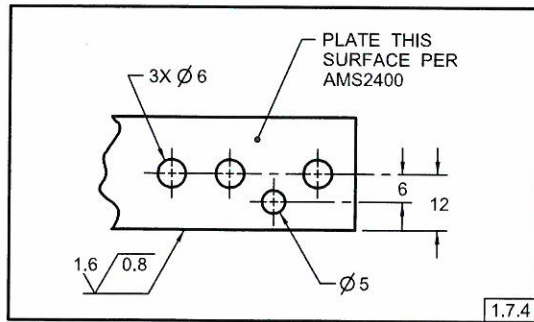

Fig. 1-16 Minimizing Leaders

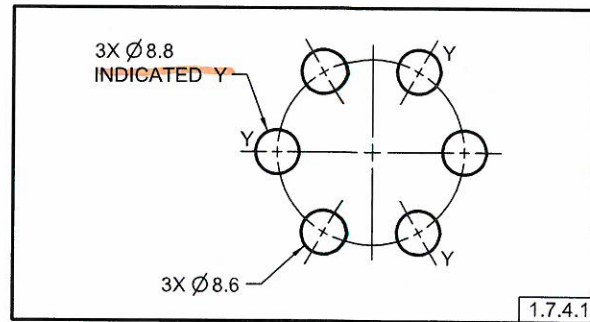

Fig. 1-15 Leader-Directed Dimensions

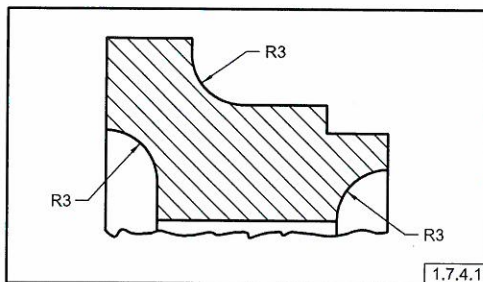
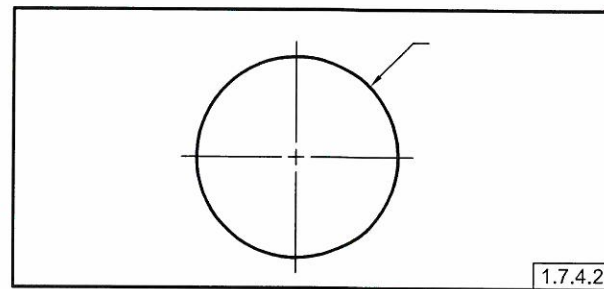

Fig. 1-17 Leader Directions



1.7.3.1 Chain Lines. In an appropriate view or section, a chain line is drawn parallel to the surface profile at a short distance from it. Dimensions are added for length and location. If applied to a surface of revolution, the indication may be shown on one side only. See Fig. 1-13, illustration (a).

1.7.3.2 Omitting Chain Line Dimensions. If the chain line clearly indicates the location and extent of the surface area, dimensions may be omitted. See Fig. 1-13, illustration (b).

1.7.3.3 Area Indication Identification. Where the desired area is shown on a direct view of the surface, the area is section lined within the chain line boundary and appropriately dimensioned. See Fig. 1-13, illustration (c).

1.7.4 Leaders (Leader Lines)

A leader is used to direct a dimension, note, or symbol to the intended place on the drawing. Normally, a leader terminates in an arrowhead. However, where it is intended for a leader to refer to a surface by ending within the outline of that surface, the leader should terminate in a dot. A leader should be an inclined straight line except for a short horizontal portion extending to the mid-height of the first or last letter or digit of the note or dimension. Two or more leaders to adjacent areas on the drawing should be drawn parallel to each other. See Fig. 1-14.

1.7.4.1 Leader-Directed Dimensions. Leader-directed dimensions are specified individually to avoid complicated leaders. See Fig. 1-15. Where too many leaders would impair the legibility of the drawing, letters or symbols should be used to identify features. See Fig. 1-16.

1.7.4.2 Circle and Arc. Where a leader is directed to a circle or an arc, its direction should be radial. See Fig. 1-17.

1.7.5 Reading Direction

Reading direction for the following specifications apply:

1.7.5.1 Notes. Notes should be placed to read from the bottom of the drawing with regard to the orientation of the drawing format.

1.7.5.2 Dimensions. Dimensions shown with dimension lines and arrowheads should be placed to read from the bottom of the drawing. See Fig. 1-18.

1.7.5.3 Baseline Dimensioning. Baseline dimensions should be shown aligned to their extension lines and read from the bottom or right side of the drawing. See Fig. 1-50.

1.7.5.4 Feature Control Frames. Feature control frames should be placed to read from the bottom of the drawing.

Fig. 1-18 Reading Direction

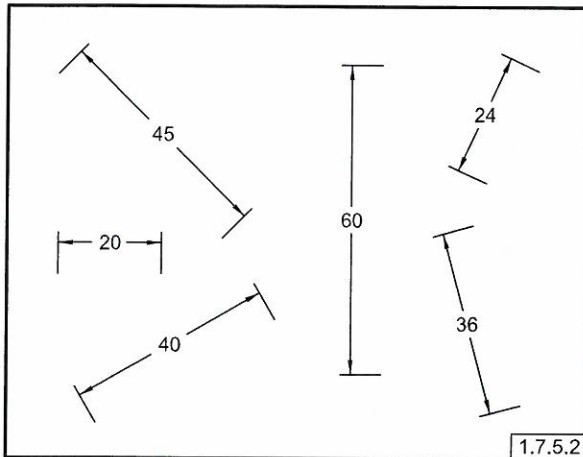
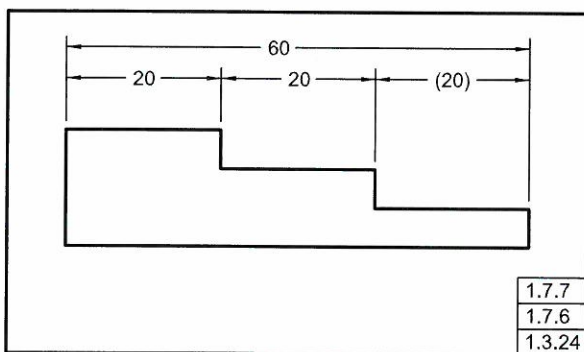

Fig. 1-19 Intermediate Reference Dimension



1.7.5.5 Datum Feature Symbols. Datum feature symbols should be placed to read from the bottom of the drawing.

1.7.6 Reference Dimensions

The method for identifying a reference dimension (or reference data) on drawings is to enclose the dimension (or data) within parentheses. See Figs. 1-19 and 1-20.

1.7.7 Overall Dimensions

Where an overall dimension is specified, one intermediate dimension is omitted or identified as a reference dimension. See Fig. 1-19. Where the intermediate dimensions are more important than the overall dimension, the overall dimension, if used, is identified as a reference dimension. See Fig. 1-20.

1.7.8 Dimensioning Within the Outline of a View

Dimensions are usually placed outside the outline of a view. Where directness of application makes it desirable, or where extension lines or leader lines would be

Fig. 1-20 Overall Reference Dimension

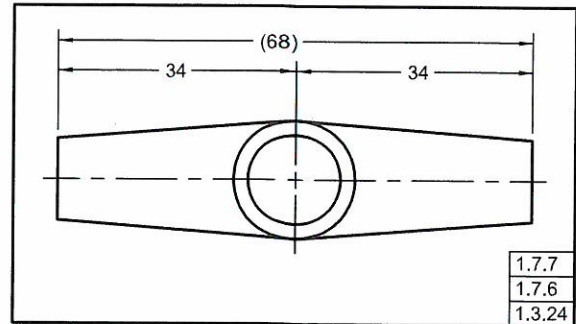
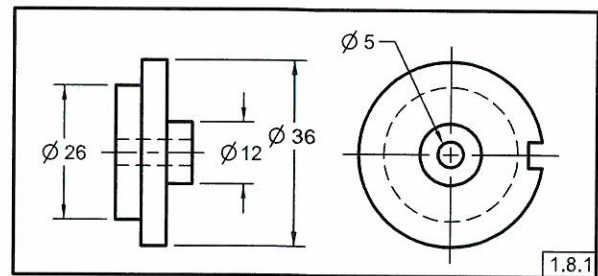

Fig. 1-21 Diameters



excessively long, dimensions may be placed within the outline of a view.

1.7.9 Dimensions Not to Scale

Agreement should exist between the pictorial presentation of a feature and its defining dimension. Where a change to a feature is made, the following, as applicable, must be observed.

(a) Where the sole authority for the product definition is a hard-copy original drawing prepared either manually or on an interactive computer graphics system, and it is not feasible to update the pictorial view of the feature, the defining dimension is to be underlined with a straight thick line. Where a basic dimension symbol is used, the line is placed beneath the symbol.

(b) Where the sole authority for the product definition is a model (digital), refer to ASME Y14.41.

1.8 DIMENSIONING FEATURES

Various characteristics and features require unique methods of dimensioning.

1.8.1 Diameters

The diameter symbol precedes all diametral values. See Fig. 1-21 and para. 3.3.7. Where the diameter of a spherical feature is specified, the diametral value is preceded by the spherical diameter symbol. See Fig. 3-11 and para. 3.3.7. Where the diameters of a number of concentric

Fig. 1-22 Radii

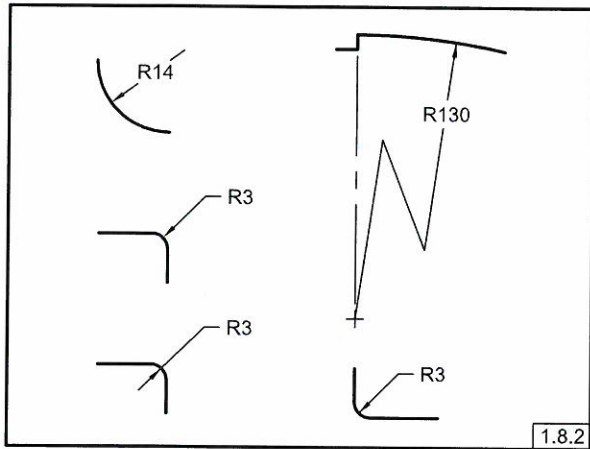
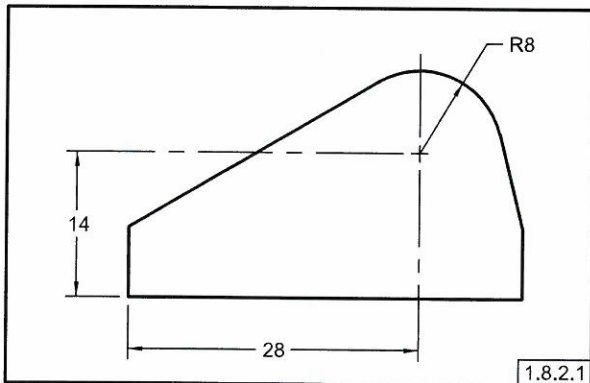

Fig. 1-23 Radius With Located Center



cylindrical features are specified, such diameters should be dimensioned in a longitudinal view if practical.

1.8.2 Radii

Each radius value is preceded by the appropriate radius symbol. See Figs. 1-22 and 3-11 and para. 3.3.7. A radius dimension line uses one arrowhead, at the arc end. An arrowhead is never used at the radius center. Where location of the center is important and space permits, a dimension line is drawn from the radius center with the arrowhead touching the arc, and the dimension is placed between the arrowhead and the center. Where space is limited, the dimension line is extended through the radius center. Where it is inconvenient to place the arrowhead between the radius center and the arc, it may be placed outside the arc with a leader. Where the center of a radius is not dimensionally located, the center shall not be indicated. See Fig. 1-22.

1.8.2.1 Center of Radius. Where a dimension is given to the center of a radius, a small cross is drawn at

Fig. 1-24 Radii With Unlocated Centers

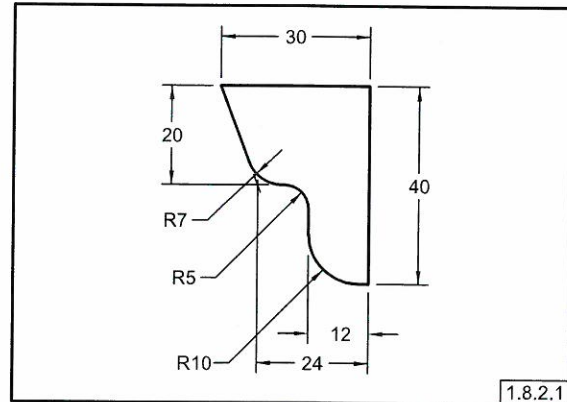
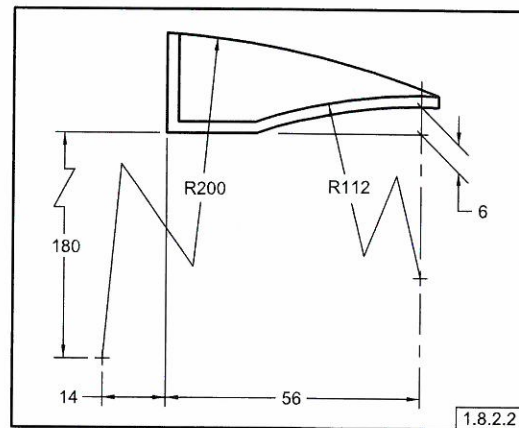

Fig. 1-25 Foreshortened Radii



the center. Extension lines and dimension lines are used to locate the center. See Fig. 1-23. Where location of the center is unimportant, the drawing must clearly show that the arc location is controlled by other dimensioned features such as tangent surfaces. See Fig. 1-24.

1.8.2.2 Foreshortened Radii. Where the center of a radius is outside the drawing or interferes with another view, the radius dimension line may be foreshortened. See Fig. 1-25. That portion of the dimension line extending from the arrowhead is radial relative to the arc. Where the radius dimension line is foreshortened and the center is located by coordinate dimensions, the dimension line locating the center is also foreshortened.

1.8.2.3 True Radius. On a 2D orthographic drawing, where a radius is dimensioned in a view that does not show the true shape of the radius, **TRUE** is added before the radius dimension. See Fig. 1-26. This practice is applicable to other foreshortened features as well as radii. See Fig. 4-28.

Fig. 1-32 Circular Arc Outline

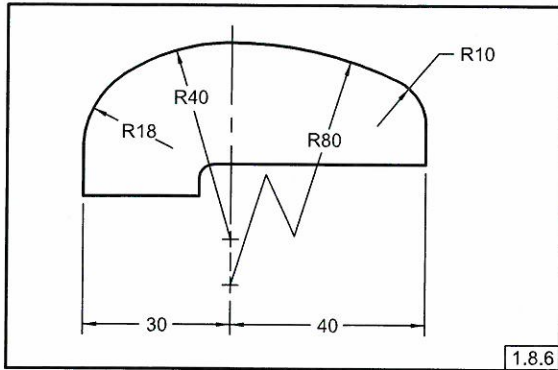

Fig. 1-33 Coordinate or Offset Outline

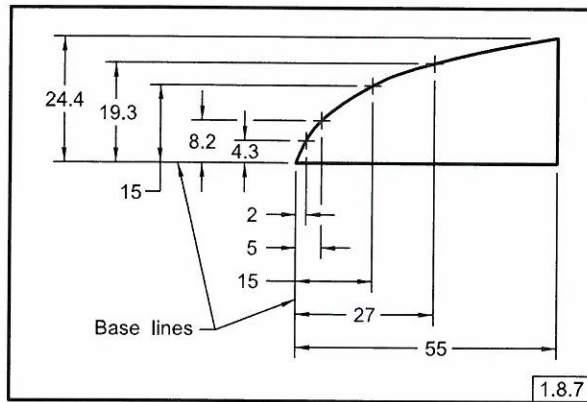

Fig. 1-34 Tabulated Outline

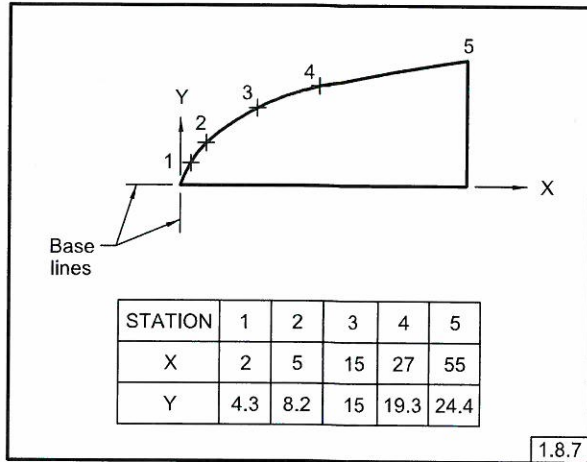
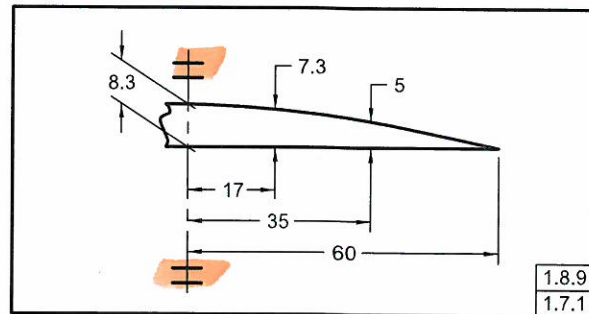

Fig. 1-35 Symmetrical Outlines



1.8.6 Outlines Consisting of Arcs

A curved outline composed of two or more arcs is dimensioned by giving the radii of all arcs and locating the necessary centers with coordinate dimensions. Other radii are located on the basis of their points of tangency. See Fig. 1-32.

1.8.7 Irregular Outlines

Irregular outlines may be dimensioned as shown in Figs. 1-33 and 1-34. Circular or noncircular outlines may be dimensioned by the rectangular coordinate or offset method. See Fig. 1-33. Coordinates are dimensioned from base lines. Where many coordinates are required to define an outline, the vertical and horizontal coordinate dimensions may be tabulated, as in Fig. 1-34.

1.8.8 Grid System

Curved pieces that represent patterns may be defined by a grid system with numbered grid lines.

1.8.9 Symmetrical Outlines

Symmetrical outlines may be dimensioned on one side of the center line of symmetry. Such is the case where,

due to the size of the part or space limitations, only part of the outline can be conveniently shown. See Fig. 1-35. One-half the outline of the symmetrical shape is shown and symmetry is indicated by applying symbols for part symmetry to the center line. See ASME Y14.2.

1.8.10 Round Holes

Round holes are dimensioned as shown in Fig. 1-36. Where it is not clear that a hole goes through, the notation THRU follows a dimension. Where multiple features are involved, additional clarification may be required. The depth dimension of a blind hole is the depth of the full diameter from the outer surface of the part. Where the depth dimension is not clear, as from a curved surface, the depth should be dimensioned pictorially. For methods of specifying blind holes, see Fig. 1-36.

1.8.11 Counterbored Holes

Counterbored holes may be specified as shown in Fig. 1-37. Where the thickness of the remaining material has significance, this thickness (rather than the depth) is dimensioned. The relationship of the counterbore and the hole shall be specified. See Figs. 7-24 and 7-25. For holes having more than one counterbore,

Fig. 1-36 Round Holes

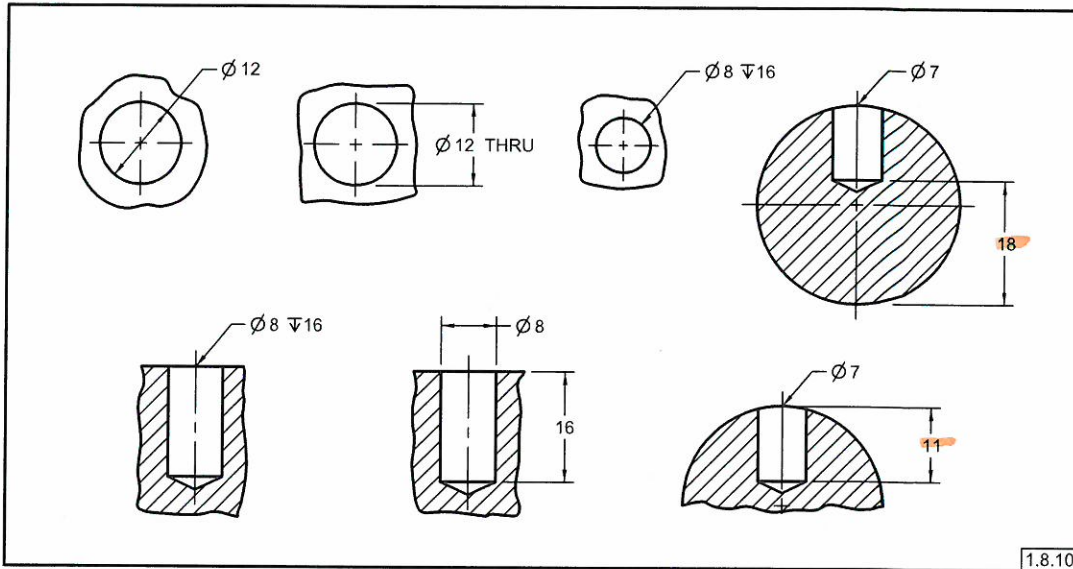

Fig. 1-37 Counterbored Holes

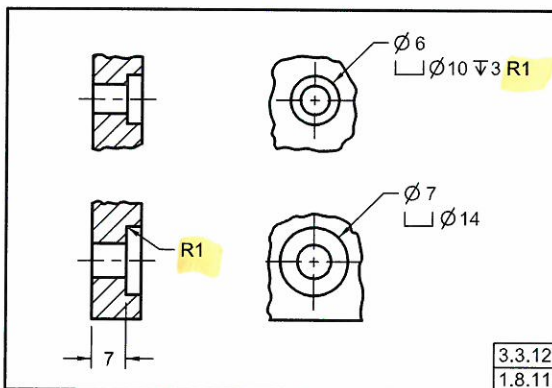
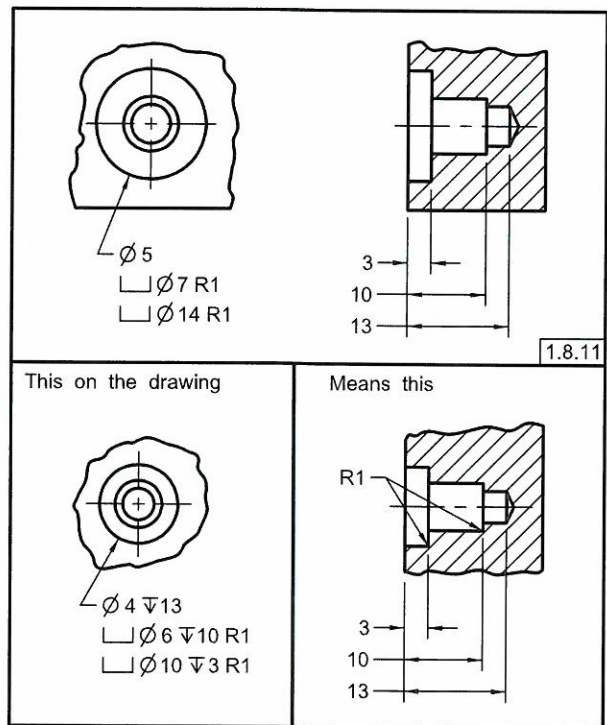

Fig. 1-38 Counterbored Holes



see Fig. 1-38. Where applicable, a fillet radius may be specified.

1.8.12 Countersunk and Counterdrilled Holes

For countersunk holes, the diameter and included angle of the countersink are specified. For counterdrilled holes, the diameter and depth of the counterdrill are specified. Specifying the included angle of the counterdrill is optional. See Fig. 1-39. The depth dimension is the depth of the full diameter of the counterdrill from the outer surface of the part.

1.8.13 Chamfered and Countersunk Holes on Curved Surfaces

Where a hole is chamfered or countersunk on a curved surface, the diameter specified on the drawing applies at the minor diameter of the chamfer or countersink. See Fig. 1-40.

1.8.14 Spotfaces

Where the diameter of the spotfaced surface is specified, either the depth or the remaining thickness of material may be specified. If no depth or remaining thickness of material is specified, the spotface is the minimum depth necessary to clean up the surface to the specified diameter. Where applicable, a fillet

Fig. 1-39 Countersunk and Counterdrilled Holes

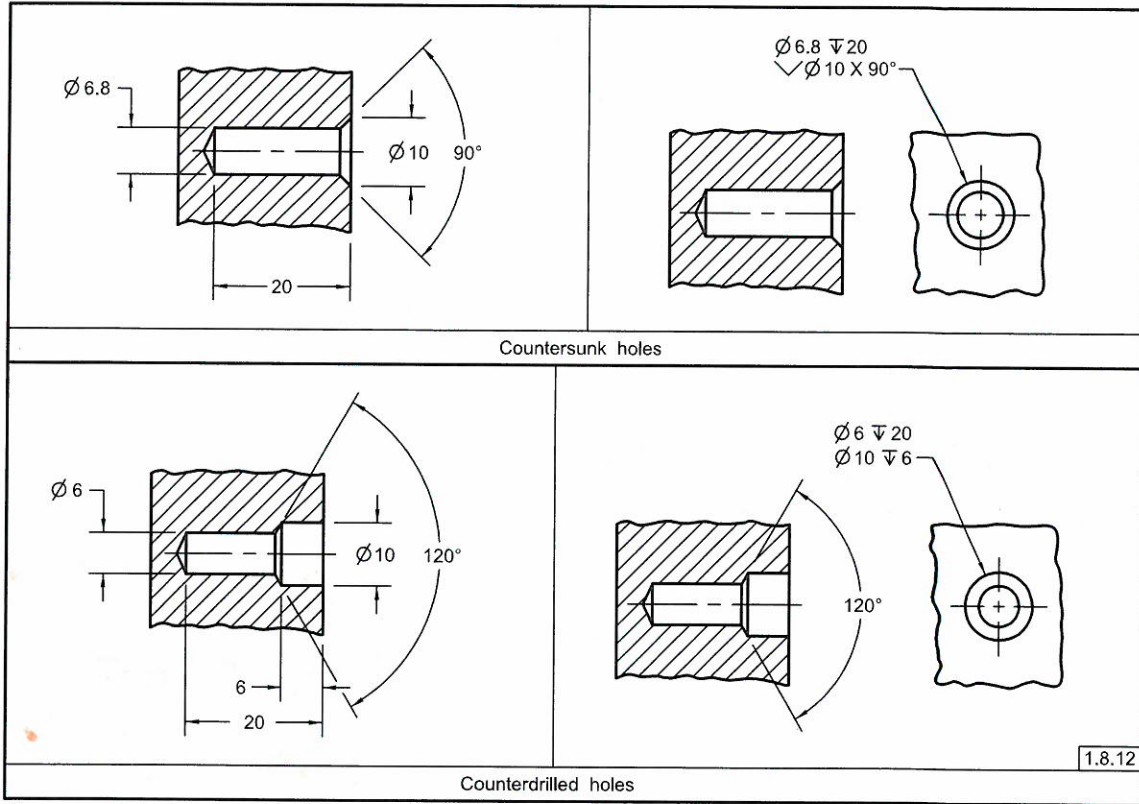
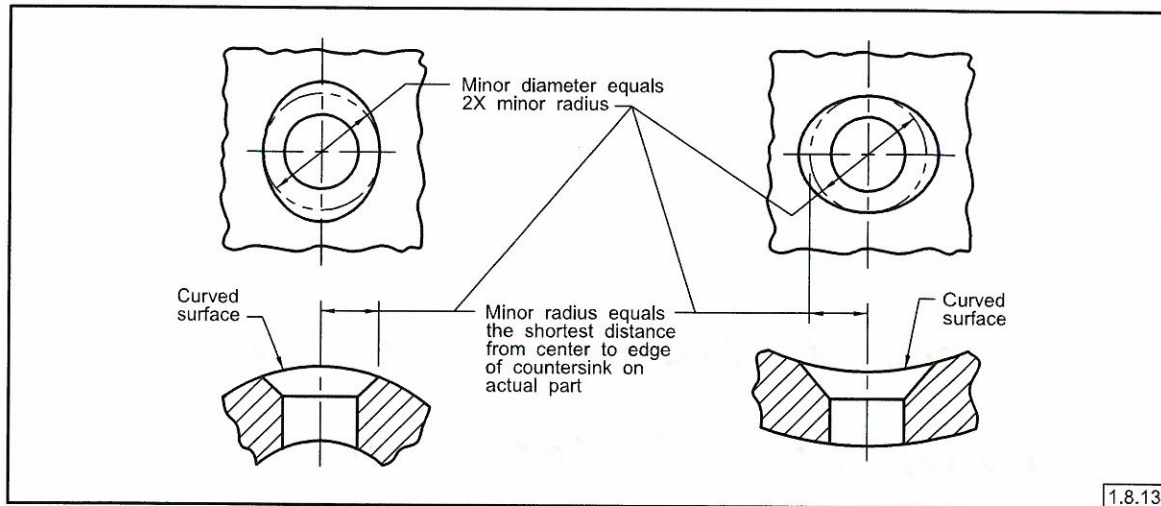

Fig. 1-40 Countersink on a Curved Surface



radius may be indicated for the spotface. In some cases, such as with a through hole, a notation may be necessary to indicate the surface to be spotfaced. See Fig. 1-41. A spotface may be specified by note only and need not be shown pictorially.

1.8.15 Machining Centers

Where machining centers are to remain on the finished part, they are indicated by a note or dimensioned on the drawing. See ASME B94.11M.

Fig. 1-41 Spotfaced Holes

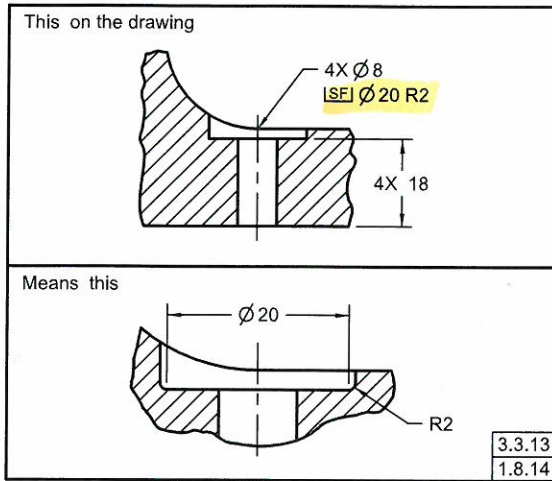

Fig. 1-42 Chamfers

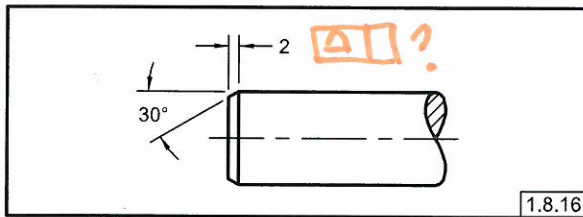
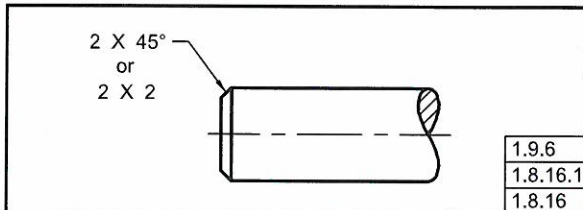

Fig. 1-43 45° Chamfer



1.8.16 Chamfers

Chamfers are dimensioned by a linear dimension and an angle, or by two linear dimensions. See Figs. 1-42 through 1-45. Where an angle and a linear dimension are specified, the linear dimension is the distance from the indicated surface of the part to the start of the chamfer. See Fig. 1-42.

1.8.16.1 Chamfers Specified by Note. A note may be used to specify 45° chamfers on perpendicular surfaces. See Fig. 1-43. This method is used only with 45° chamfers, as the linear value applies in either direction.

1.8.16.2 Round Holes. Where the edge of a round hole is chamfered, the practice of para. 1.8.16.1 is followed, except where the chamfer diameter requires

Fig. 1-44 Internal Chamfers

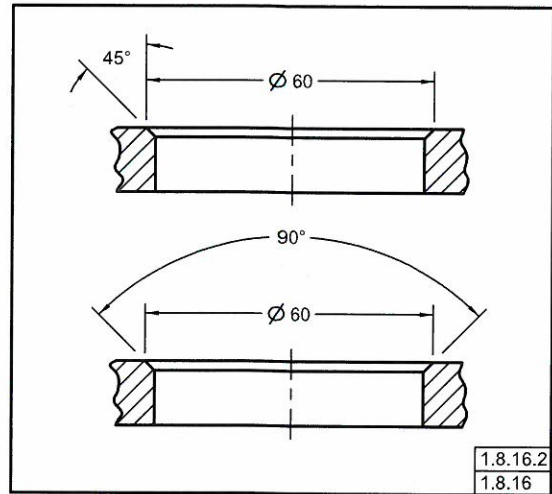

Fig. 1-45 Chamfers Between Surfaces at Other Than 90°

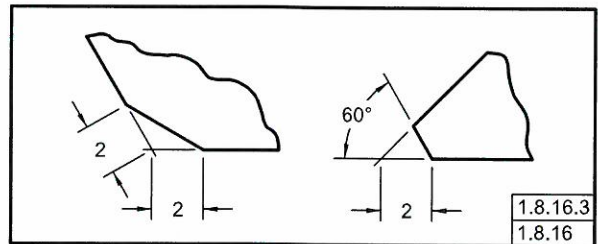
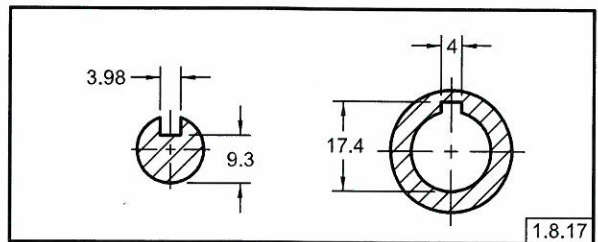

Fig. 1-46 Keyseats



dimensional control. See Fig. 1-44. This type of control may also be applied to the chamfer diameter on a shaft.

1.8.16.3 Non-Perpendicular Intersecting Surfaces. Two acceptable methods of dimensioning chamfers for surfaces intersecting at other than right angles are shown in Fig. 1-45.

1.8.17 Keyseats

Keyseats are dimensioned by width, depth, location, and if required, length. The depth may be dimensioned from the opposite side of the shaft or hole. See Fig. 1-46.

Fig. 1-47 Knurls

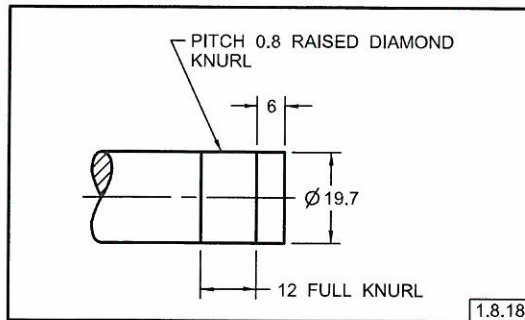
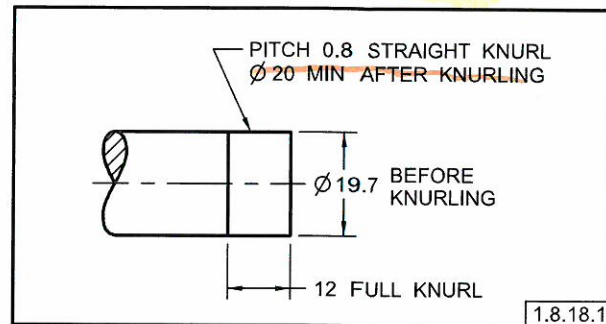

Fig. 1-48 Knurls for Press Fits



1.8.18 Knurling

Knurling is specified in terms of type, pitch, and diameter before and after knurling. Where control is not required, the diameter after knurling is omitted. Where only a portion of a feature requires knurling, the location and length of the knurl shall be specified. See Fig. 1-47.

1.8.18.1 Knurling for Press Fit. Where required to provide a press fit between parts, knurling is specified by a note that includes the type of knurl required, its pitch, the toleranced diameter of the feature before knurling, and the minimum acceptable diameter after knurling. See Fig. 1-48.

1.8.18.2 Knurling Standard. For information on inch knurling, see ANSI/ASME B94.6.

1.8.19 Rods and Tubing Details

Rods and tubing may be dimensioned in three coordinate directions and toleranced using geometric tolerances or by specifying the straight lengths, bend radii, angles of bend, and angles of twist for all portions of each feature. This may be done by means of auxiliary views, tabulation, or supplementary data.

1.8.20 Screw Threads

Methods of specifying and dimensioning screw threads are covered in ASME Y14.6.

1.8.21 Surface Texture

Methods of specifying surface texture requirements are covered in ASME Y14.36M. For additional information, see ASME B46.1.

1.8.22 Involute Splines

Methods of specifying involute spline requirements are covered in the ANSI B92 series of standards.

1.8.23 Castings, Forgings, and Molded Parts

Methods of specifying requirements peculiar to castings, forgings, and molded parts are covered in ASME Y14.8.

1.9 LOCATION OF FEATURES

Rectangular coordinate or polar coordinate dimensions locate features with respect to one another, and as a group or individually, from a datum or an origin. The features that establish this datum or origin must be identified. See para. 7.2.1.3. Round holes or other features of symmetrical contour are located by giving distances, or distances and directions, to the feature centers.

1.9.1 Rectangular Coordinate Dimensioning

Where rectangular coordinate dimensioning is used to locate features, linear dimensions specify distances in coordinate directions from two or three mutually perpendicular planes. See Fig. 1-49. Coordinate dimensioning must clearly indicate which features of the part establish these planes. For methods to accomplish this, see Figs. 4-2 and 4-8.

1.9.2 Rectangular Coordinate Dimensioning Without Dimension Lines

Dimensions may be shown on extension lines without the use of dimension lines or arrowheads. The base lines are indicated as zero coordinates. See Fig. 1-50.

1.9.3 Tabular Dimensioning

Tabular dimensioning is a type of rectangular coordinate dimensioning in which dimensions from mutually perpendicular planes are listed in a table on the drawing, rather than on the pictorial delineation. See Fig. 1-51. Tables are prepared in any suitable manner that adequately locates the features.

Fig. 1-49 Rectangular Coordinate Dimensioning

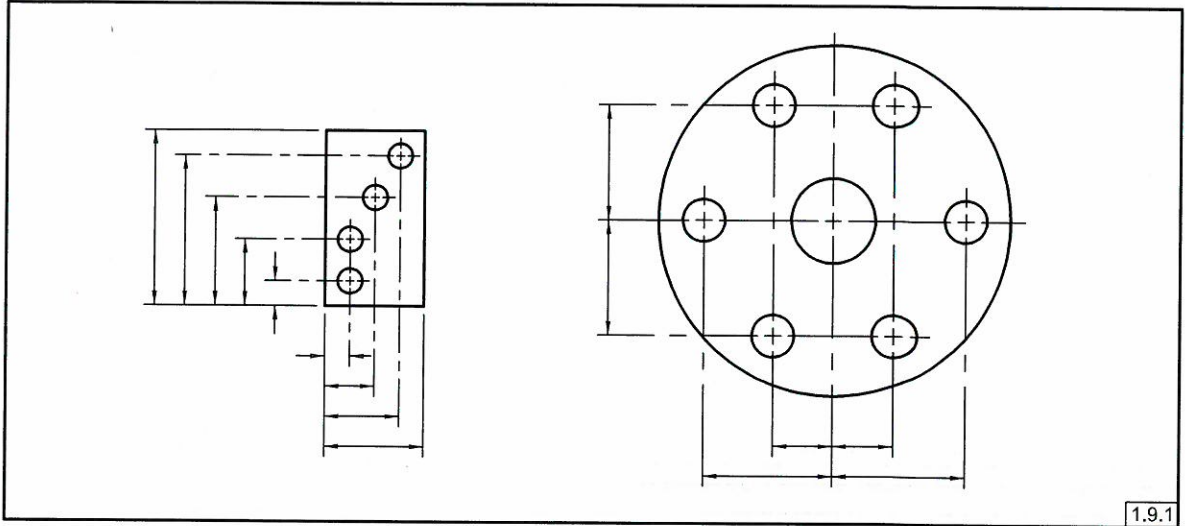

1.9.1

Fig. 1-50 Rectangular Coordinate Dimensioning Without Dimension Lines

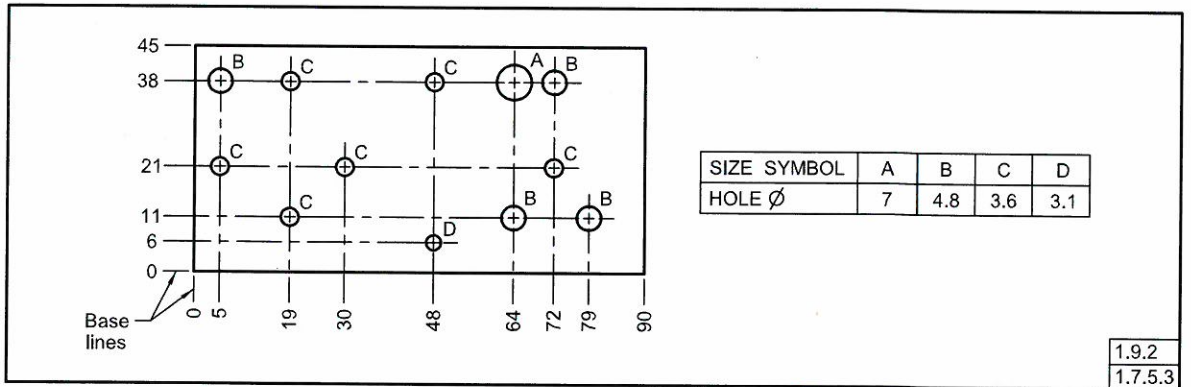

1.9.2

1.7.5.3

Fig. 1-51 Rectangular Coordinate Dimensioning in Tabular Form

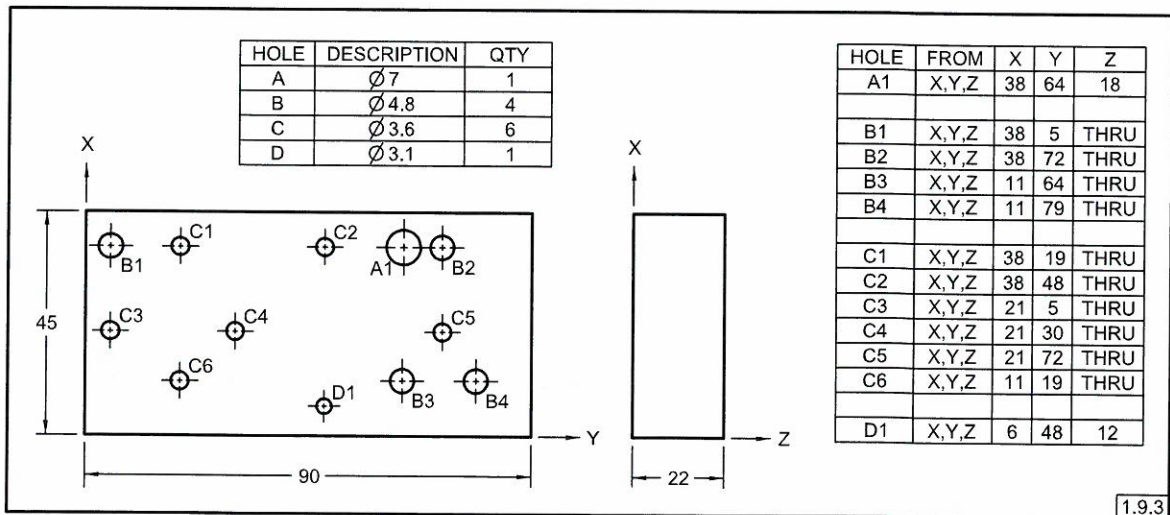

1.9.3

Fig. 1-52 Polar Coordinate Dimensioning

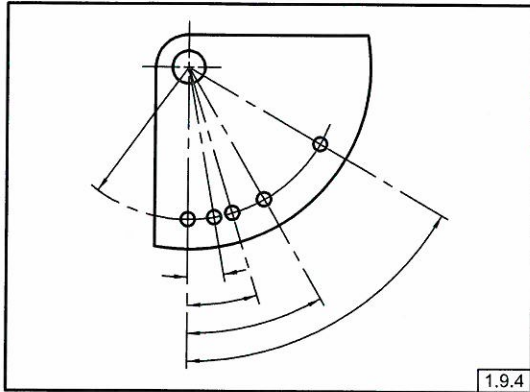

1.9.4

Fig. 1-53 Repetitive Features

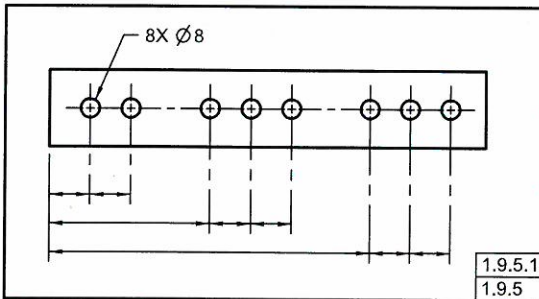

1.9.5.1
1.9.5

Fig. 1-54 Repetitive Features

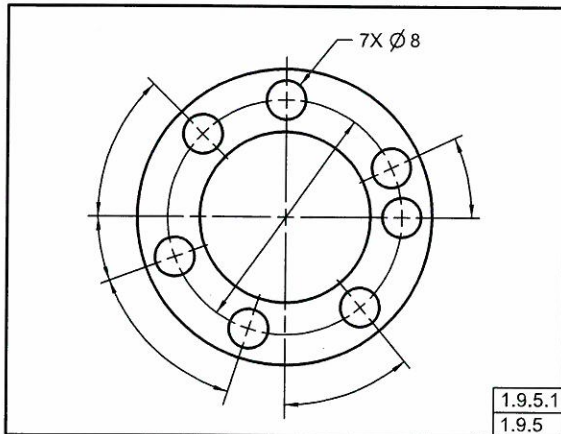

1.9.5.1
1.9.5

1.9.4 Polar Coordinate Dimensioning

Where polar coordinate dimensioning is used to locate features, a linear and an angular dimension specifies a distance from a fixed point at an angular direction from two or three mutually perpendicular planes. The fixed point is the intersection of these planes. See Fig. 1-52.

Fig. 1-55 Repetitive Features and Dimensions

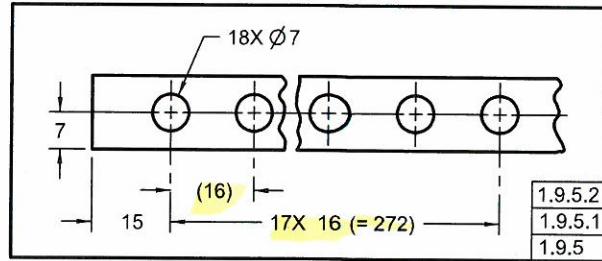

1.9.5.2
1.9.5.1
1.9.5

Fig. 1-56 Repetitive Features and Dimensions

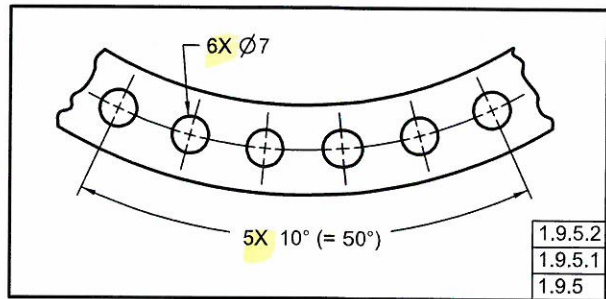

1.9.5.2
1.9.5.1
1.9.5

Fig. 1-57 Repetitive Features and Dimensions

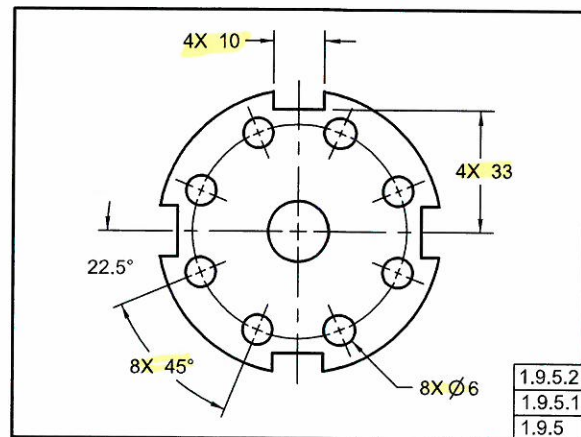

1.9.5.2
1.9.5.1
1.9.5

1.9.5 Repetitive Features or Dimensions

Repetitive features or dimensions may be specified by the use of an X in conjunction with a numeral to indicate the "number of places" required. See Figs. 1-53 through 1-57. Where used with a basic dimension, the X may be placed either inside or outside the basic dimension frame.

A space is used between the X and the dimension. See Figs. 4-39 and 7-16.

1.9.5.1 Series and Patterns. Features, such as holes and slots, which are repeated in a series or pattern, may be specified by giving the required number of features and an X followed by the size dimension of the feature. A space is used between the X and the dimension. See Figs. 1-53 through 1-57.

1.9.5.2 Spacing. Equal spacing of features in a series or pattern may be specified by giving the required number of spaces and an X, followed by the applicable dimension. A space is used between the X and the

dimension. See Figs. 1-55 through 1-57. Where it is difficult to distinguish between the dimension and the number of spaces, as in Fig. 1-55, one space may be dimensioned and identified as reference.

1.9.6 Use of X to Indicate "By"

An X may be used to indicate "by" between coordinate dimensions as shown in Fig. 1-43. In such cases, the X shall be preceded and followed by one character space.

NOTE: Where the practices described in paras. 1.9.5 and 1.9.6 are used on the same drawing; care must be taken to be sure each usage is clear.